



LA PARMENTIÈRE

GARLIC PEELER

TYPES 8A-15A

USE

Especially designed for peeling garlic, this powerful machine ensures perfect results for the processed produce and is quick and simple to use.

PERFORMANCE

•the processed garlic has an attractive appearance, due to:

- 1. A special device which ensures finished peeling without damage to the product (height adjustable shoe in the bowl),
- 2. The calibrated holes in the wheel.

•optimum hourly output:

TYPE: 8A 40 to 80 kg.

TYPE: 15A 60 to 120 kg.

These output rates take into account both the size and quality of the product.

CHARACTERISTICS

- Machine made entirely of stainless steel.
- nickel-chrome wheel with countersunk holes,
- motor: 1HP (Type 8A) – 2.5 kW (Type 15A)
- Manual or pneumatic cylinder operated door.
- Capacity:
Type 8A: 6 to 8 kg.
Type 15A: 12 to 15 kg.

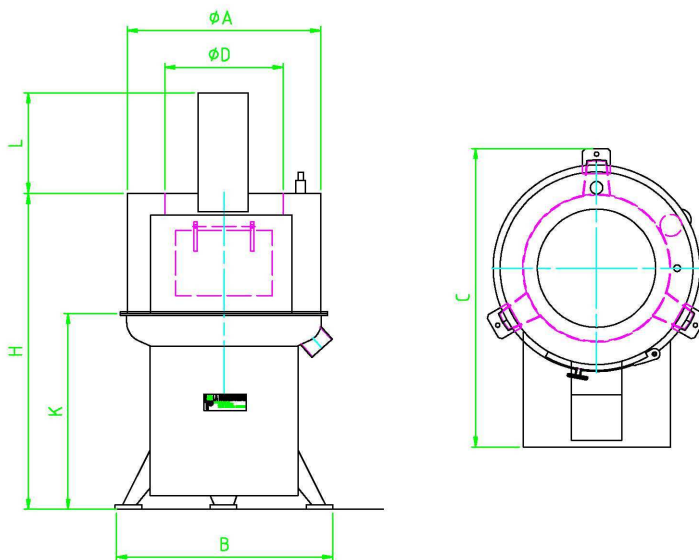

TYPE	Dia. A	B	C	Dia. D	H	K
8 A	460	465	810	240	750	450
15 A	725	740	875	350	1095	700



LA PARMENTIÈRE

P. BLACHE ET Cie

Maison fondée en 1899

S.A au capital de 172 325 €

Z.I 7 rue Lavoisier 77330 OZOIR LA FERRIERE - FRANCE

TEL: +33 (0) 1 64 40 00 12 - FAX: +33 (0) 1 64 40 08 50

Email: Jps.Laparmeniere@wanadoo.fr - Web site: www.Laparmeniere.com

R.C.S MELUN B 784 780 181